

Scivias

for

Violin, Viola, Violoncello, Percussion, Piano
and Interactive Electronics

by

Keith A. Hamel

Duration: 12 min.

Performance Rights: SOCAN

Copyright: © 2011, Keith A. Hamel

Commissioned by: New Music Concerts, Toronto, Canada

Premiere Performance: April 10, 2011 by New Music Concerts at the Music Gallery, Toronto, Canada.



Interactive Performance Setup

This composition includes live interactive processing of all instruments using the MaxMSP software application running on a Macintosh computer. During performance, MaxMSP receives audio signals from the instruments and distributes electronically processed sounds to speakers placed in the hall. MaxMSP is controlled by a NoteAbilityPro score which can either be run on the same computer or on a second computer which is connected to the first computer through a network. All the software required for the performance and detailed instructions on the operation of the software can be obtained from the composer – Keith Hamel (hamel@interchange.ubc.ca).

The audio setup requires separate microphone inputs from violin, viola, cello, piano and percussion. At least 2 microphones should be used on the percussion instruments. The microphones inputs are connected to an audio interface that is connected to the computer running MaxMSP. There are 4 channels of audio output and one mixed channel that should be sent to a sub-woofer. A mixer should be used between the audio interface and the speakers to allow audio levels to be controlled during performance. However, the 4 output channels should remain discrete since the MaxMSP software controls all sound spatialization. The 4 output channels should be connected to powered speakers placed in the four corners of the hall:

1- Front-left 2 - Front-right 3 - Rear-left 4 - Rear-right.

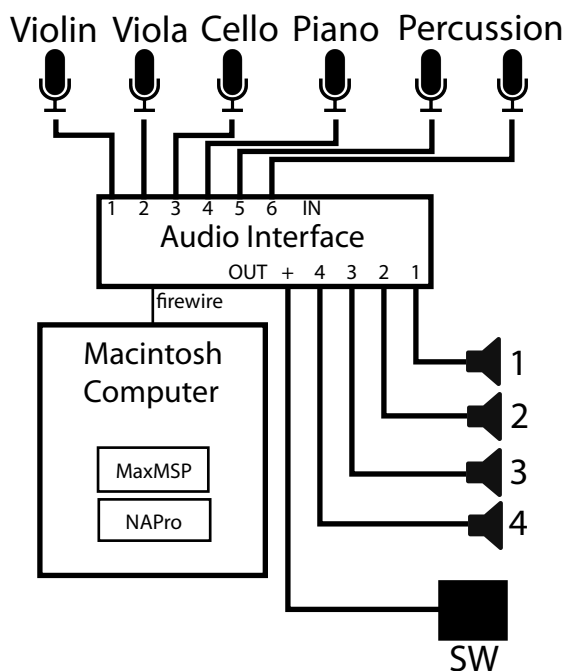

Performance Notes

Strings

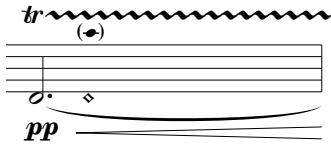

Trill between the stopped note and the natural harmonic located at the same finger position. This is done by changing the pressure of the finger on the string. The speed of the trill can change gradually over time.

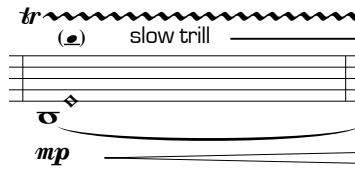

Trill between the stopped note and the artificial harmonic a 4th higher (and sounding 2 octaves higher.) The speed of the trill can change gradually over time.

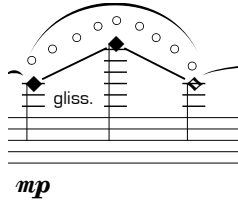

A natural harmonic gliss beginning and ending on the specified notes.

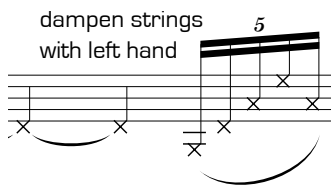

Dampen all the strings with the left hand and bow on the indicated strings. This should produce quiet noise and very little perceivable pitch.

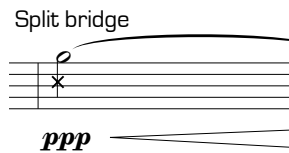

Bow slowly directly on the bridge so that the bow hair is split between the sul pont and sub pont areas. The resulting sound should mostly be noise with some high frequency sounds occurring from time to time.

Piano



Place the side of the hand firmly across the strings of the piano close the hammers and play the specified pitches on the keyboard. The strings should be muted so that only a strong percussive sound and some high partials are heard. The dynamic indicates the strength of the keyboard strike rather than the resulting volume.

Percussion

- 1 Suspended Cymbal (large)
- 1 Sizzle Cymbal (medium)
- 2 Wood blocks (or temple blocks)
- 5 Tom-toms (largest should be at least 16" in diameter)
- 2 Tam-tams (small & medium)
- Crotales (1 octave)
- Vibraphone (motor is not used)

The percussion staff uses the following instrument configuration:

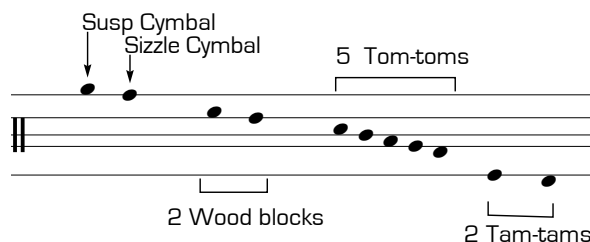

2

5

Vn *sul tasto* *pp* *mp* *p* gliss. ord.
 Vla *mp* *p* gliss. ord. gliss.
 Vc *mp* *ppp* *pp* gliss. * tr (♯)
 Per *pp* *pp* *p* scratch surface of tam-tam (metal)
 Pno *p*
 Max1 0.008 matrixPreset 2;
 Max3 3.193 volCycle 1 1 1 1 0 0
 Max4 *pp*
 Max5 phrase 1a

10

Vn

Vla

Vc

Per

Pno

Max1

Max2

Max3

Max4

Max5

mf

p

pp

mp

Crotales bowed

phrase 1b

4

13

A

♩ = 112

♩ = 56

Vn

Vla

Vc

Per

Pno

Susp. Cymbal
Sizzle Cymbal

Vibraphone

(motor off)

mf *ff*

ppp 7

ff

Max1

Max2

Max3

Max4

Max5

0.000
pafPreset 12

1.219
matrixPreset 9;
spRecallPreset 2;
spDelayRand 1;
auRecallPreset khDrone4;
pan1Rand 1;
pan2Rand 1;
pan3Rand 0;
whichTracker 0;

2.796
au1BrightnessOnOff 0

0.872
volCycle 1 1 1 0 0 0

18

Vn *mp* *p* *pp*
 Vla *mp* *p* *pp*
 Vc *mp* *p* *pp*
 Per *pp* *mp* *pp* *mp*
 Pno *sfz* damp with side of hand *pp*
 Max1 [0.250] matrixPreset 5;
 Max2 [1.250] au4BinShiftOnOff 1
 Max3
 Max4
 Max5 bell G crot G bell E crot E
 [0.000] volCycle 1 1 1 0 0
 5-15 24-50 3-15

6

23

♩ = 112

♩ = 56

Vn *mf* *pp* *PPP* sul E

Vla *mf* *pp* *PPP* poco sul pont

Vc *mf* *pp* *pp* tr *pp* **

Per 15 *ff* *p* *f*
 2 Cymbals
 2 Wood blocks
 5 Tom-toms

Pno *ff*

** trill between stopped note and artificial harmonic a 4th higher.

Max1 0.355 matrixPreset 4; spRecallPreset 1; spDelayMax 200; spDelayRand 1

Max2 0.059 au4BinShiftOnOff 0

Max3

Max4

Max5 2.000 volCycle 1 1 1 0 0 0

27

Vn *mp* *pp* *p*

Vla *mp* *ppp* *pp* *p*

Vc *mp* *ppp* *p*

Per *pp* *mp*

Pno *ppp* *ppp*

Max1 *1.138* *0.219*
pafPreset 2 *matrixPreset 5*

Max2

Max3

Max4 phrase 6a
65 22

Max5 *0.000*
volCycle 1 1 1 1 0 0

gliss. poco sul pont gliss. **7**

Crotales bowed

15 8

7 6

8

31

B

$\text{♩} = 112$

Vn

Vla

Vc

sul pont

2 Cymbals
2 Wood blocks

5 Tom-toms

ff

pp

Per

Pno

2.684

matrixPreset 6;
whichTracker 0;
pan1Rand 1;
pan2Rand 1;
pan3Rand 0;
spDelayMax 200;
spDelayRand 1;

0.000

volCycle 1 1 1 0 0 0

Max1

Max2

Max3

Max4

Max5

35

Vn *ord.*
sul D *ppp* *mp* *mp*
gliss. gliss. gliss.

Vla *ord. senza vib.*
p molto espressivo *mp*

Vc *ord.* *tr* (♯) slow trill fast trill slow trill
mp *mf*

2 Tam-tams

Per *mp* *p* *ppp*

Pno *fff*

Max1
Max2
Max3
Max4
Max5 *phrase 2*

10
40

Vn *pp* *p*

Vla normal vib. *p*

Vc *pp* gliss. *p*

Per *pp* *mp*

Pno *ppp* *ppp* *pp*

Max1

Max2

Max3

Max4 bowed cym 71 40

Max5

44

C

Vn *mp* *pp* *p*
 Vla *mp* *pp* *p*
 Vc *mp* *pp* *p*
 Per
 Pno *f*
 Max1 3.540 fmHarm 2.01 2.242 matrixPreset 7; auRecallPreset3 khGate5; auRecallPreset khDrone6; auRecallPreset4 khGrain3; spDelayRand 1; auMixL3 0.75 1000; spDelayMax 500; spDelayRand 1; whichTracker 4; ptVoil 120 2000; pafSwitch 1; fmPreset 52; fmVoil 35 2000; 1.375 pafTranspose 0; 1.452 ptRange 53.86
 Max2
 Max3
 Max4
 Max5 0.500 volCycle 0 0 0 1 0

12
50

Musical score for Vn, Vla, Vc, Per, Pno, and Max1-5. The score is in 4/4 time and features various dynamics and articulations.

Vn: Melodic line with dynamics *mp* and *f*.
Vla: Melodic line with dynamics *mp* and *ff*. Includes a section marked with Roman numerals II and III.
Vc: Melodic line with dynamics *mp* and *ff*.
Per: Percussion part for 5 Tom-toms and Vibraphone. Dynamics include *mp*, *f*, *p*, *mf*, and *ff*.
Pno: Piano accompaniment with dynamics *f*.
Max1-5: Empty staves for additional instruments.

Annotations include a box labeled "5 Tom-toms" and another labeled "Vibraphone". A dynamic marking *f* is present in the Vibraphone part.

0.801
fmPreset 7

56

This musical score page contains six systems of staves, labeled Vn, Vla, Vc, Per, Pno, and Max1 through Max5. The Vn, Vla, and Vc staves are grouped together with a brace on the left. The Per, Pno, and Max1-5 staves are also grouped with a brace on the left. The Vn, Vla, and Vc staves contain whole rests for all six measures. The Vla staff features a melodic line with eighth-note patterns and slurs. The Per staff contains a rhythmic pattern of eighth notes with accents. The Pno staff contains a rhythmic pattern of eighth notes with accents. The Max1, Max2, and Max3 staves are empty. The Max4 staff has a single purple eighth note in the second measure. The Max5 staff is empty.

14
62

Musical score for measures 14-18. The score includes staves for Violin (Vn), Viola (Vla), Violoncello (Vc), Percussion (Per), Piano (Pno), and five Max tracks (Max1-5).
- Vn: Treble clef, starting with a *p* dynamic. Features sustained notes with a gliss. (glissando) marking at the end.
- Vla: Bass clef, playing a rhythmic pattern of eighth notes with accents.
- Vc: Bass clef, starting with a *ff* dynamic and a Pizz. (pizzicato) marking.
- Per: Treble clef, playing a rhythmic pattern of eighth notes with accents.
- Pno: Treble and Bass clefs, playing a rhythmic pattern of eighth notes with accents.
- Max1-3: Empty staves.
- Max4: Treble clef, contains a single purple note in the second measure.
- Max5: Bass clef, contains the text "bell E" in the second measure.

24-35
a

68

Vn
mp *pp* *p*

Vla

Vc
ff *pp* Arco

Per

Pno

Max1

Max2

Max3

Max4

Max5
bell D bell E bell F

23-35 24-35 25-35

The musical score is arranged in a system with seven staves. The top staff is for Violin (Vn), the second for Viola (Vla), and the third for Violoncello (Vc). The fourth staff is for Percussion (Per), the fifth for Piano (Pno), and the last three staves (Max1, Max2, Max3) are empty. The bottom two staves (Max4, Max5) are for Mallets (Max4 and Max5), with notes for bell D, bell E, and bell F. Dynamics include *mp*, *pp*, *p*, and *ff*. Performance instructions include *Arco* and *ff*. The score includes various musical notations such as slurs, accents, and dynamic markings.

16
74

D

Vn

Vla

Vc

p

p

p

gliss.

Per

2 Wood blocks

f

f

Pno

Max1

Max2

Max3

Max4

Max5

sung C

sung D

74 25

75 25

80

Musical score for measures 80-84. The score includes staves for Violin (Vn), Viola (Vla), Violoncello (Vc), Percussion (Per), Piano (Pno), and five Max tracks (Max1-5). The Vn, Vla, and Vc parts feature long, sustained notes with glissando markings and dynamic markings of *mp* and *p*. The Per part consists of a rhythmic pattern of eighth notes. The Pno part features a rhythmic pattern of eighth notes. The Max4 and Max5 tracks contain specific notes labeled "sung F" and "sung E" with red circles and the numbers "77 25" and "76 25" respectively.

Musical score for measures 18-20. The score includes parts for Violin (Vn), Viola (Vla), Violoncello (Vc), Percussion (Per), Piano (Pno), and five Max parts (Max1 to Max5).
- **Vn:** Starts with a rest, then plays a series of eighth notes. Fingering III and IV is indicated. Dynamics include *f*.
- **Vla:** Starts with a rest, then plays a single note. Dynamics include *ff*.
- **Vc:** Starts with a rest, then plays a single note. Dynamics include *ff*.
- **Per:** Plays a rhythmic pattern of eighth notes. Dynamics include *f* and *ff*. A box labeled "2 Wood blocks" is positioned above the staff.
- **Pno:** Plays a melodic line with eighth notes. Dynamics include *f*.
- **Max1-3:** Empty staves.
- **Max4:** Empty staff with a red circle and the number "79 20" below it.
- **Max5:** Empty staff with a red circle and the number "80 20" below it.

92

Vn

Vla

Vc

Per

Pno

Max1

Max2

Max3

Max4

Max5

ff

ff

f

Arco

2 Wood blocks

f

81 20

80 20

20
98

Musical score for Vn, Vla, Vc, Per, Pno, and Max1-5. The score is in 4/4 time and features a variety of rhythmic patterns and dynamics. The Vn part starts with a *mp* dynamic. The Vla part is marked *f* and includes an *Arco* instruction. The Vc part is marked *mf*. The Per part features a *f* dynamic. The Pno part is marked *f*. The Max1-5 parts are empty.

104

E

Vn *mf* gliss.

Vla *mf*

Vc *sfz* *ff* *mf* Pizz. Arco

2 Wood blocks

Per *f*

Pno *mp* *f mp*

Max1
Max2
Max3
Max4
Max5

22
110

Vn

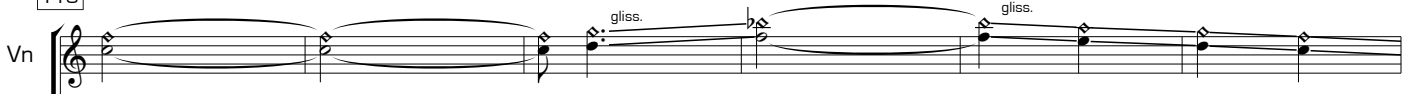

Vla

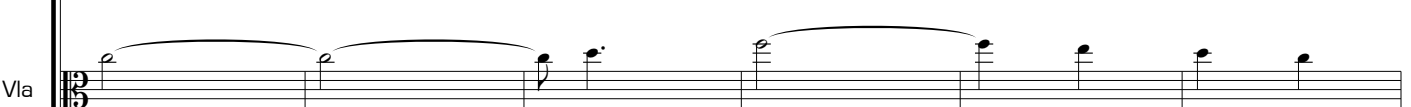

Vc



Per

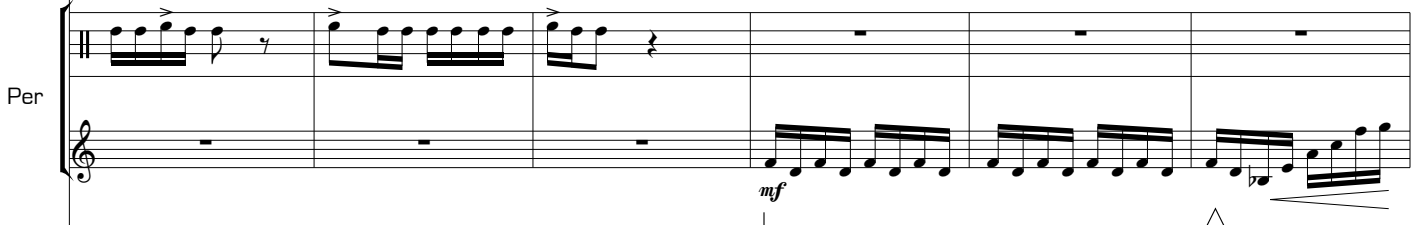

Pno

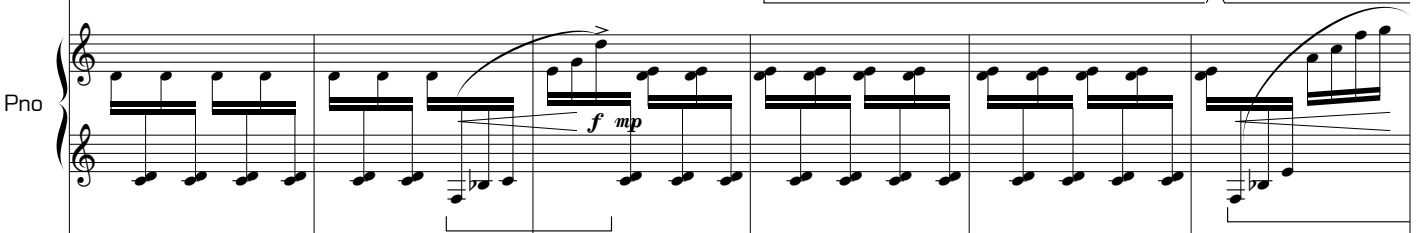

Max1

0.352
matrixPreset 8

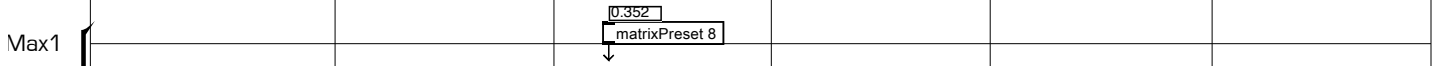

Max2

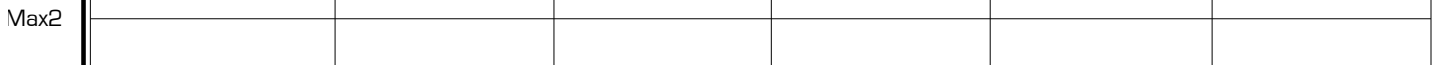

Max3



Max4

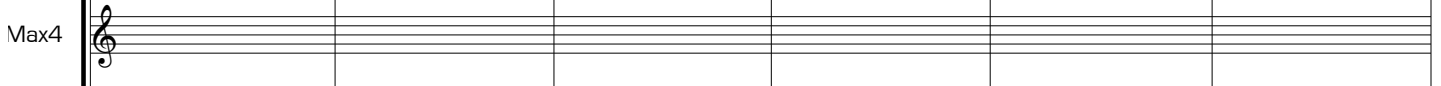

Max5

0.500
volCycle 0 0 0 0 1 0

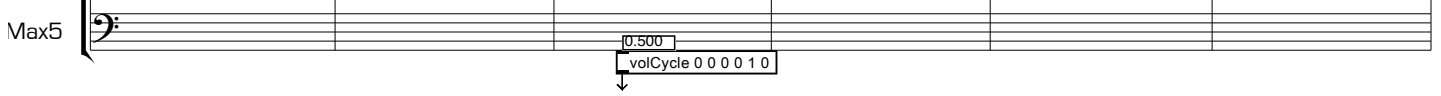

116

This musical score page features six staves. The top three staves are for Violin (Vn), Viola (Vla), and Violoncello (Vc). The Vn staff includes glissando markings and a dynamic marking of *p*. The Vla and Vc staves show sustained notes and rhythmic patterns. The fourth staff is for Percussion (Per), featuring a complex rhythmic pattern with accents. The fifth staff is for Piano (Pno), with dynamic markings of *f* and *mp*. The bottom three staves, labeled Max1, Max2, and Max3, are empty. The bottom two staves, labeled Max4 and Max5, are also empty but include treble and bass clefs respectively.

This musical score page features six staves. The first three staves are for Violin (Vn), Viola (Vla), and Violoncello (Vc). The Vn staff has a treble clef and contains long notes with glissando markings and dynamic markings of *p* and *mp*. The Vla staff has an alto clef and includes dynamic markings of *pp*, *p*, and *mp*. The Vc staff has a bass clef and features a rhythmic pattern of eighth notes. The fourth staff is for Percussion (Per) with a treble clef, showing a complex rhythmic pattern with accents and slurs. The fifth staff is for Piano (Pno) with a grand staff (treble and bass clefs), featuring chords and dynamic markings of *f* and *mp*. The bottom three staves, labeled Max1, Max2, and Max3, are empty. The bottom two staves, labeled Max4 and Max5, have treble and bass clefs respectively and are also empty.

128

F

The musical score consists of six staves. The first three staves are for Vn, Vla, and Vc. The Vn staff starts with a glissando and dynamic markings of *f*, *mp*, and *pp*. The Vla staff has *ff* and *mp* markings, with *Pizz.* and *Arco* instructions. The Vc staff has a *v* marking. The fourth staff is for Percussion (Per), featuring triplets and dynamic markings of *ff* and *p*. The fifth staff is for Piano (Pno), with *mp* marking and a *poco a poco cresc....* instruction. The sixth staff is for MIDI controllers (Max1-5), with various annotations: Max1 has a box with parameters like `spDelayMax 400;` and `whichTracker 1;`; Max2 has `pafTranspose 0` and `au+BrightnessOnOff 1`; Max3 has `ptRange 67 91`; Max5 has `volCycle 1 0 0 1 0`. Time markers 0.736, 1.378, 0.750, and 1.309 are placed above the MIDI controller staves.

26

134

espressivo

Vn *p* *mp* *pp*

Vla *mp*

Vc *mp*

Per *f* *mf*

Pno

Max1

Max2

Max3

Max4

Max5 *crotaleBb*

140

Musical score for Vn, Vla, Vc, Per, Pno, Max1, Max2, Max3, Max4, and Max5. The score includes dynamic markings such as *mp*, *mf*, *pp*, and *f*, and features triplets and slurs. The Vn part starts with a triplet of eighth notes, followed by a slur over a triplet of quarter notes, and then a *mf* dynamic. The Vla part has a *pp* dynamic. The Vc part has a *pp* dynamic. The Per part has a *mf* dynamic. The Pno part has a *f* dynamic. The Max1-4 parts are empty. The Max5 part has a *crotaleD* marking.

crotaleD

28

146

Musical score for Vn, Vla, Vc, Per, Pno, Max1, Max2, Max3, Max4, and Max5. The score includes dynamic markings (mp, mf, pp, 3f) and articulation (trills, slurs). The Max4 and Max5 staves contain MIDI-style notes with labels 'convolve2' and 'crotaleE'.

Vn: *mp* 3, *mf*

Vla: *pp*, *mp*

Vc: *pp*, *mp*

Per: *3f*, *mf*

Pno: *convolve2*

Max4: *convolve2*, 73 50

Max5: *crotaleE*, 3 15

152

Vn

Vla

Vc

Per

Pno

Max1

Max2

Max3

Max4

Max5

pp *mp* *f* *pp* *mp* *f* *mf* *f*

pp *mp* *mp* *f* *mf* *f* *mf* *f*

crotaleD

2 15

30

158

Musical score for measures 30-34. The score includes parts for Violin (Vn), Viola (Vla), Violoncello (Vc), Percussion (Per), Piano (Pno), and five Max tracks (Max1-5).

Vn: Treble clef. Measure 30: *pp* quarter rest. Measure 31: *mp* triplet eighth notes (B4, C5, B4), *f* triplet eighth notes (A4, G4, F4). Measure 32: *f* quarter notes (E4, D4). Measure 33: *f* quarter notes (C4, B3). Measure 34: *f* quarter notes (A3, G3).

Vla: Alto clef. Measure 30: *pp* quarter notes (C4, B3). Measure 31: *pp* quarter notes (A3, G3). Measure 32: *mp* quarter notes (F3, E3). Measure 33: *mp* quarter notes (D3, C3). Measure 34: *mp* quarter notes (B2, A2).

Vc: Bass clef. Measure 30: *pp* quarter notes (C3, B2). Measure 31: *mp* quarter notes (A2, G2). Measure 32: *pp* quarter notes (F2, E2). Measure 33: *pp* quarter notes (D2, C2). Measure 34: *mp* quarter notes (B1, A1).

Per: Treble clef. Measure 30: *f* triplet eighth notes (B4, C5, B4). Measure 31: *f* triplet eighth notes (A4, G4, F4). Measure 32: *f* quarter notes (E4, D4). Measure 33: *mf* triplet eighth notes (B4, C5, B4). Measure 34: *mf* triplet eighth notes (A4, G4, F4).

Pno: Treble and Bass clefs. Treble clef: Measure 30-34: eighth-note chords (e.g., G4-B4, A4-G4, F4-E4, E4-D4, D4-C4, C4-B3, B3-A3, A3-G3, G3-F3, F3-E3, E3-D3, D3-C3, C3-B2, B2-A2, A2-G2, G2-F2, F2-E2, E2-D2, D2-C2, C2-B1, B1-A1, A1-G1, G1-F1, F1-E1, E1-D1, D1-C1, C1-B0, B0-A0, A0-G0, G0-F0, F0-E0, E0-D0, D0-C0, C0-B-1, B-1-A-1, A-1-G-1, G-1-F-1, F-1-E-1, E-1-D-1, D-1-C-1, C-1-B-2, B-2-A-2, A-2-G-2, G-2-F-2, F-2-E-2, E-2-D-2, D-2-C-2, C-2-B-3, B-3-A-3, A-3-G-3, G-3-F-3, F-3-E-3, E-3-D-3, D-3-C-3, C-3-B-4, B-4-A-4, A-4-G-4, G-4-F-4, F-4-E-4, E-4-D-4, D-4-C-4, C-4-B-5, B-5-A-5, A-5-G-5, G-5-F-5, F-5-E-5, E-5-D-5, D-5-C-5, C-5-B-6, B-6-A-6, A-6-G-6, G-6-F-6, F-6-E-6, E-6-D-6, D-6-C-6, C-6-B-7, B-7-A-7, A-7-G-7, G-7-F-7, F-7-E-7, E-7-D-7, D-7-C-7, C-7-B-8, B-8-A-8, A-8-G-8, G-8-F-8, F-8-E-8, E-8-D-8, D-8-C-8, C-8-B-9, B-9-A-9, A-9-G-9, G-9-F-9, F-9-E-9, E-9-D-9, D-9-C-9, C-9-B-10, B-10-A-10, A-10-G-10, G-10-F-10, F-10-E-10, E-10-D-10, D-10-C-10, C-10-B-11, B-11-A-11, A-11-G-11, G-11-F-11, F-11-E-11, E-11-D-11, D-11-C-11, C-11-B-12, B-12-A-12, A-12-G-12, G-12-F-12, F-12-E-12, E-12-D-12, D-12-C-12, C-12-B-13, B-13-A-13, A-13-G-13, G-13-F-13, F-13-E-13, E-13-D-13, D-13-C-13, C-13-B-14, B-14-A-14, A-14-G-14, G-14-F-14, F-14-E-14, E-14-D-14, D-14-C-14, C-14-B-15, B-15-A-15, A-15-G-15, G-15-F-15, F-15-E-15, E-15-D-15, D-15-C-15, C-15-B-16, B-16-A-16, A-16-G-16, G-16-F-16, F-16-E-16, E-16-D-16, D-16-C-16, C-16-B-17, B-17-A-17, A-17-G-17, G-17-F-17, F-17-E-17, E-17-D-17, D-17-C-17, C-17-B-18, B-18-A-18, A-18-G-18, G-18-F-18, F-18-E-18, E-18-D-18, D-18-C-18, C-18-B-19, B-19-A-19, A-19-G-19, G-19-F-19, F-19-E-19, E-19-D-19, D-19-C-19, C-19-B-20, B-20-A-20, A-20-G-20, G-20-F-20, F-20-E-20, E-20-D-20, D-20-C-20, C-20-B-21, B-21-A-21, A-21-G-21, G-21-F-21, F-21-E-21, E-21-D-21, D-21-C-21, C-21-B-22, B-22-A-22, A-22-G-22, G-22-F-22, F-22-E-22, E-22-D-22, D-22-C-22, C-22-B-23, B-23-A-23, A-23-G-23, G-23-F-23, F-23-E-23, E-23-D-23, D-23-C-23, C-23-B-24, B-24-A-24, A-24-G-24, G-24-F-24, F-24-E-24, E-24-D-24, D-24-C-24, C-24-B-25, B-25-A-25, A-25-G-25, G-25-F-25, F-25-E-25, E-25-D-25, D-25-C-25, C-25-B-26, B-26-A-26, A-26-G-26, G-26-F-26, F-26-E-26, E-26-D-26, D-26-C-26, C-26-B-27, B-27-A-27, A-27-G-27, G-27-F-27, F-27-E-27, E-27-D-27, D-27-C-27, C-27-B-28, B-28-A-28, A-28-G-28, G-28-F-28, F-28-E-28, E-28-D-28, D-28-C-28, C-28-B-29, B-29-A-29, A-29-G-29, G-29-F-29, F-29-E-29, E-29-D-29, D-29-C-29, C-29-B-30, B-30-A-30, A-30-G-30, G-30-F-30, F-30-E-30, E-30-D-30, D-30-C-30, C-30-B-31, B-31-A-31, A-31-G-31, G-31-F-31, F-31-E-31, E-31-D-31, D-31-C-31, C-31-B-32, B-32-A-32, A-32-G-32, G-32-F-32, F-32-E-32, E-32-D-32, D-32-C-32, C-32-B-33, B-33-A-33, A-33-G-33, G-33-F-33, F-33-E-33, E-33-D-33, D-33-C-33, C-33-B-34, B-34-A-34, A-34-G-34, G-34-F-34, F-34-E-34, E-34-D-34, D-34-C-34, C-34-B-35, B-35-A-35, A-35-G-35, G-35-F-35, F-35-E-35, E-35-D-35, D-35-C-35, C-35-B-36, B-36-A-36, A-36-G-36, G-36-F-36, F-36-E-36, E-36-D-36, D-36-C-36, C-36-B-37, B-37-A-37, A-37-G-37, G-37-F-37, F-37-E-37, E-37-D-37, D-37-C-37, C-37-B-38, B-38-A-38, A-38-G-38, G-38-F-38, F-38-E-38, E-38-D-38, D-38-C-38, C-38-B-39, B-39-A-39, A-39-G-39, G-39-F-39, F-39-E-39, E-39-D-39, D-39-C-39, C-39-B-40, B-40-A-40, A-40-G-40, G-40-F-40, F-40-E-40, E-40-D-40, D-40-C-40, C-40-B-41, B-41-A-41, A-41-G-41, G-41-F-41, F-41-E-41, E-41-D-41, D-41-C-41, C-41-B-42, B-42-A-42, A-42-G-42, G-42-F-42, F-42-E-42, E-42-D-42, D-42-C-42, C-42-B-43, B-43-A-43, A-43-G-43, G-43-F-43, F-43-E-43, E-43-D-43, D-43-C-43, C-43-B-44, B-44-A-44, A-44-G-44, G-44-F-44, F-44-E-44, E-44-D-44, D-44-C-44, C-44-B-45, B-45-A-45, A-45-G-45, G-45-F-45, F-45-E-45, E-45-D-45, D-45-C-45, C-45-B-46, B-46-A-46, A-46-G-46, G-46-F-46, F-46-E-46, E-46-D-46, D-46-C-46, C-46-B-47, B-47-A-47, A-47-G-47, G-47-F-47, F-47-E-47, E-47-D-47, D-47-C-47, C-47-B-48, B-48-A-48, A-48-G-48, G-48-F-48, F-48-E-48, E-48-D-48, D-48-C-48, C-48-B-49, B-49-A-49, A-49-G-49, G-49-F-49, F-49-E-49, E-49-D-49, D-49-C-49, C-49-B-50, B-50-A-50, A-50-G-50, G-50-F-50, F-50-E-50, E-50-D-50, D-50-C-50, C-50-B-51, B-51-A-51, A-51-G-51, G-51-F-51, F-51-E-51, E-51-D-51, D-51-C-51, C-51-B-52, B-52-A-52, A-52-G-52, G-52-F-52, F-52-E-52, E-52-D-52, D-52-C-52, C-52-B-53, B-53-A-53, A-53-G-53, G-53-F-53, F-53-E-53, E-53-D-53, D-53-C-53, C-53-B-54, B-54-A-54, A-54-G-54, G-54-F-54, F-54-E-54, E-54-D-54, D-54-C-54, C-54-B-55, B-55-A-55, A-55-G-55, G-55-F-55, F-55-E-55, E-55-D-55, D-55-C-55, C-55-B-56, B-56-A-56, A-56-G-56, G-56-F-56, F-56-E-56, E-56-D-56, D-56-C-56, C-56-B-57, B-57-A-57, A-57-G-57, G-57-F-57, F-57-E-57, E-57-D-57, D-57-C-57, C-57-B-58, B-58-A-58, A-58-G-58, G-58-F-58, F-58-E-58, E-58-D-58, D-58-C-58, C-58-B-59, B-59-A-59, A-59-G-59, G-59-F-59, F-59-E-59, E-59-D-59, D-59-C-59, C-59-B-60, B-60-A-60, A-60-G-60, G-60-F-60, F-60-E-60, E-60-D-60, D-60-C-60, C-60-B-61, B-61-A-61, A-61-G-61, G-61-F-61, F-61-E-61, E-61-D-61, D-61-C-61, C-61-B-62, B-62-A-62, A-62-G-62, G-62-F-62, F-62-E-62, E-62-D-62, D-62-C-62, C-62-B-63, B-63-A-63, A-63-G-63, G-63-F-63, F-63-E-63, E-63-D-63, D-63-C-63, C-63-B-64, B-64-A-64, A-64-G-64, G-64-F-64, F-64-E-64, E-64-D-64, D-64-C-64, C-64-B-65, B-65-A-65, A-65-G-65, G-65-F-65, F-65-E-65, E-65-D-65, D-65-C-65, C-65-B-66, B-66-A-66, A-66-G-66, G-66-F-66, F-66-E-66, E-66-D-66, D-66-C-66, C-66-B-67, B-67-A-67, A-67-G-67, G-67-F-67, F-67-E-67, E-67-D-67, D-67-C-67, C-67-B-68, B-68-A-68, A-68-G-68, G-68-F-68, F-68-E-68, E-68-D-68, D-68-C-68, C-68-B-69, B-69-A-69, A-69-G-69, G-69-F-69, F-69-E-69, E-69-D-69, D-69-C-69, C-69-B-70, B-70-A-70, A-70-G-70, G-70-F-70, F-70-E-70, E-70-D-70, D-70-C-70, C-70-B-71, B-71-A-71, A-71-G-71, G-71-F-71, F-71-E-71, E-71-D-71, D-71-C-71, C-71-B-72, B-72-A-72, A-72-G-72, G-72-F-72, F-72-E-72, E-72-D-72, D-72-C-72, C-72-B-73, B-73-A-73, A-73-G-73, G-73-F-73, F-73-E-73, E-73-D-73, D-73-C-73, C-73-B-74, B-74-A-74, A-74-G-74, G-74-F-74, F-74-E-74, E-74-D-74, D-74-C-74, C-74-B-75, B-75-A-75, A-75-G-75, G-75-F-75, F-75-E-75, E-75-D-75, D-75-C-75, C-75-B-76, B-76-A-76, A-76-G-76, G-76-F-76, F-76-E-76, E-76-D-76, D-76-C-76, C-76-B-77, B-77-A-77, A-77-G-77, G-77-F-77, F-77-E-77, E-77-D-77, D-77-C-77, C-77-B-78, B-78-A-78, A-78-G-78, G-78-F-78, F-78-E-78, E-78-D-78, D-78-C-78, C-78-B-79, B-79-A-79, A-79-G-79, G-79-F-79, F-79-E-79, E-79-D-79, D-79-C-79, C-79-B-80, B-80-A-80, A-80-G-80, G-80-F-80, F-80-E-80, E-80-D-80, D-80-C-80, C-80-B-81, B-81-A-81, A-81-G-81, G-81-F-81, F-81-E-81, E-81-D-81, D-81-C-81, C-81-B-82, B-82-A-82, A-82-G-82, G-82-F-82, F-82-E-82, E-82-D-82, D-82-C-82, C-82-B-83, B-83-A-83, A-83-G-83, G-83-F-83, F-83-E-83, E-83-D-83, D-83-C-83, C-83-B-84, B-84-A-84, A-84-G-84, G-84-F-84, F-84-E-84, E-84-D-84, D-84-C-84, C-84-B-85, B-85-A-85, A-85-G-85, G-85-F-85, F-85-E-85, E-85-D-85, D-85-C-85, C-85-B-86, B-86-A-86, A-86-G-86, G-86-F-86, F-86-E-86, E-86-D-86, D-86-C-86, C-86-B-87, B-87-A-87, A-87-G-87, G-87-F-87, F-87-E-87, E-87-D-87, D-87-C-87, C-87-B-88, B-88-A-88, A-88-G-88, G-88-F-88, F-88-E-88, E-88-D-88, D-88-C-88, C-88-B-89, B-89-A-89, A-89-G-89, G-89-F-89, F-89-E-89, E-89-D-89, D-89-C-89, C-89-B-90, B-90-A-90, A-90-G-90, G-90-F-90, F-90-E-90, E-90-D-90, D-90-C-90, C-90-B-91, B-91-A-91, A-91-G-91, G-91-F-91, F-91-E-91, E-91-D-91, D-91-C-91, C-91-B-92, B-92-A-92, A-92-G-92, G-92-F-92, F-92-E-92, E-92-D-92, D-92-C-92, C-92-B-93, B-93-A-93, A-93-G-93, G-93-F-93, F-93-E-93, E-93-D-93, D-93-C-93, C-93-B-94, B-94-A-94, A-94-G-94, G-94-F-94, F-94-E-94, E-94-D-94, D-94-C-94, C-94-B-95, B-95-A-95, A-95-G-95, G-95-F-95, F-95-E-95, E-95-D-95, D-95-C-95, C-95-B-96, B-96-A-96, A-96-G-96, G-96-F-96, F-96-E-96, E-96-D-96, D-96-C-96, C-96-B-97, B-97-A-97, A-97-G-97, G-97-F-97, F-97-E-97, E-97-D-97, D-97-C-97, C-97-B-98, B-98-A-98, A-98-G-98, G-98-F-98, F-98-E-98, E-98-D-98, D-98-C-98, C-98-B-99, B-99-A-99, A-99-G-99, G-99-F-99, F-99-E-99, E-99-D-99, D-99-C-99, C-99-B-100, B-100-A-100, A-100-G-100, G-100-F-100, F-100-E-100, E-100-D-100, D-100-C-100, C-100-B-101, B-101-A-101, A-101-G-101, G-101-F-101, F-101-E-101, E-101-D-101, D-101-C-101, C-101-B-102, B-102-A-102, A-102-G-102, G-102-F-102, F-102-E-102, E-102-D-102, D-102-C-102, C-102-B-103, B-103-A-103, A-103-G-103, G-103-F-103, F-103-E-103, E-103-D-103, D-103-C-103, C-103-B-104, B-104-A-104, A-104-G-104, G-104-F-104, F-104-E-104, E-104-D-104, D-104-C-104, C-104-B-105, B-105-A-105, A-105-G-105, G-105-F-105, F-105-E-105, E-105-D-105, D-105-C-105, C-105-B-106, B-106-A-106, A-106-G-106, G-106-F-106, F-106-E-106, E-106-D-106, D-106-C-106, C-106-B-107, B-107-A-107, A-107-G-107, G-107-F-107, F-107-E-107, E-107-D-107, D-107-C-107, C-107-B-108, B-108-A-108, A-108-G-108, G-108-F-108, F-108-E-108, E-108-D-108, D-108-C-108, C-108-B-109, B-109-A-109, A-109-G-109, G-109-F-109, F-109-E-109, E-109-D-109, D-109-C-109, C-109-B-110, B-110-A-110, A-110-G-110, G-110-F-110, F-110-E-110, E-110-D-110, D-110-C-110, C-110-B-111, B-111-A-111, A-111-G-111, G-111-F-111, F-111-E-111, E-111-D-111, D-111-C-111, C-111-B-112, B-112-A-112, A-112-G-112, G-112-F-112, F-112-E-112, E-112-D-112, D-112-C-112, C-112-B-113, B-113-A-113, A-113-G-113, G-113-F-113, F-113-E-113, E-113-D-113, D-113-C-113, C-113-B-114, B-114-A-114, A-114-G-114, G-114-F-114, F-114-E-114, E-114-D-114, D-114-C-114, C-114-B-115, B-115-A-115, A-115-G-115, G-115-F-115, F-115-E-115, E-115-D-115, D-115-C-115, C-115-B-116, B-116-A-116, A-116-G-116, G-116-F-116, F-116-E-116, E-116-D-116, D-116-C-116, C-116-B-117, B-117-A-117, A-117-G-117, G-117-F-117, F-117-E-117, E-117-D-117, D-117-C-117, C-117-B-118, B-118-A-118, A-118-G-118, G-118-F-118, F-118-E-118, E-118-D-118, D-118-C-118, C-118-B-119, B-119-A-119, A-119-G-119, G-119-F-119, F-119-E-119, E-119-D-119, D-119-C-119, C-119-B-120, B-120-A-120, A-120-G-120, G-120-F-120, F-120-E-120, E-120-D-120, D-120-C-120, C-120-B-121, B-121-A-121, A-121-G-121, G-121-F-121, F-121-E-121, E-121-D-121, D-121-C-121, C-121-B-122, B-122-A-122, A-122-G-122, G-122-F-122, F-122-E-122, E-122-D-122, D-122-C-122, C-122-B-123, B-123-A-123, A-123-G-123, G-123-F-123, F-123-E-123, E-123-D-123, D-123-C-123, C-123-B-124, B-124-A-124, A-124-G-124, G-124-F-124, F-124-E-124, E-124-D-124, D-124-C-124, C-124-B-125, B-125-A-125, A-125-G-125, G-125-F-125, F-125-E-125, E-125-D-125, D-125-C-125, C-125-B-126, B-126-A-126, A-126-G-126, G-126-F-126, F-126-E-126, E-126-D-126, D-126-C-126, C-126-B-127, B-127-A-127, A-127-G-127, G-127-F-127, F-127-E-127, E-127-D-127, D-127-C-127, C-127-B-128, B-128-A-128, A-128-G-128, G-128-F-128, F-128-E-128, E-128-D-128, D-128-C-128, C-128-B-129, B-129-A-129, A-129-G-129, G-129-F-129, F-129-E-129, E-129-D-129, D-129-C-129, C-129-B-130, B-130-A-130, A-130-G-130, G-130-F-130, F-130-E-130, E-130-D-130, D-130-C-130, C-130-B-131, B-131-A-131, A-131-G-131, G-131-F-131, F-131-E-131, E-131-D-131, D-131-C-131, C-131-B-132, B-132-A-132, A-132-G-132, G-132-F-132, F-132-E-132, E-132-D-132, D-132-C-132, C-132-B-133, B-133-A-133, A-133-G-133, G-133-F-133, F-133-E-133, E-133-D-133, D-133-C-133, C-133-B-134, B-134-A-134, A-134-G-134, G-134-F-134, F-134-E-134, E-134-D-134, D-134-C-134, C-134-B-135, B-135-A-135, A-135-G-135, G-135-F-135, F-135-E-135, E-135-D-135, D-135-C-135, C-135-B-136, B-136-A-136, A-136-G-136, G-136-F-136, F-136-E-136, E-136-D-136, D-136-C-136, C-136-B-137, B-137-A-137, A-137-G-137, G-137-F-137, F-137-E-137, E-137-D-137, D-137-C-137, C-137-B-138, B-138-A-138, A-138-G-138, G-138-F-138, F-138-E-138, E-138-D-138, D-138-C-138, C-138-B-139, B-139-A-139, A-139-G-139, G-139-F-139, F-139-E-139, E-139-D-139, D-139-C-139, C-139-B-140, B-140-A-140, A-140-G-140, G-140-F-140, F-140-E-140, E-140-D-140, D-140-C-140, C-140-B-141, B-141-A-141, A-141-G-141, G-141-F-141, F-141-E-141, E-141-D-141, D-141-C-141, C-141-B-142, B-142-A-142, A-142-G-142, G-142-F-142, F-142-E-142, E-142-D-142, D-142-C-142, C-142-B-143, B-143-A-143, A-143-G-143, G-143-F-143, F-143-E-143, E-143-D-143, D-143-C-143, C-143-B-144, B-144-A-144, A-144-G-144, G-144-F-144, F-144-E-144, E-144-D-144, D-144-C-144, C-144-B-145, B-145-A-145, A-145-G-145, G-145-F-145, F-145-E-145, E-145-D-145, D-145-C-145, C-145-B-146, B-146-A-146, A-146-G-146, G-146-F-146, F-146-E-146, E-146-D-146, D-146-C-146, C-146-B-147, B-147-A-147, A-147-G-147, G-147-F-147, F-147-E-147, E-147-D-147, D-147-C-147, C-147-B-148, B-148-A-148, A-148-G-148, G-148-F-148, F-148-E-148, E-148-D-148, D-148-C-148, C-148-B-149, B-149-A-149, A-149-G-149, G-149-F-149, F-149-E-149, E-149-D-149, D-149-C-149, C-149-B-150, B-150-A-150, A-150-G-150, G-150-F-150, F-150-E-150, E-150-D-150, D-150-C-150, C-150-B-151, B-151-A-151, A-151-G-151, G-151-F-151, F-151-E-151, E-151-D-151, D-151-C-151, C-151-B-152, B-152-A-152, A-152-G-152, G-152-F-152, F-152-E-152, E-152-D-152, D-152-C-152, C-152-B-153, B-153-A-153, A-153-G-153, G-153-F-153, F-153-E-153, E-153-D-153, D-153-C-153, C-153-B-154, B-154-A-154, A-154-G-154, G-154-F-154, F-154-E-154, E-154-D-154, D-154-C-154, C-154-B-155, B-155-A-155, A-155-G-155, G-155-F-155, F-155-E-155, E-155-D-155, D-155-C-155, C-155-B-156, B-156-A-156, A-156-G-156, G-156-F-156, F-156-E-156, E-156-D-156, D-156-C-156, C-156-B-157, B-157-A-157, A-157-G-157, G-157-F-157, F-157-E-157, E-157-D-157, D-157-C-157, C-157-B-158, B-158-A-158, A-158-G-158, G-158-F-158, F-158-E-158, E-158-D-158, D-158-C-158, C-158-B-159, B-159-A-159, A-159-G-159, G-159-F-159, F-159-E-159, E-159-D-159, D-159-C-159, C-159-B-160, B-160-A-160, A-160-G-160, G-160-F-160, F-160-E-160, E-160-D-160, D-160-C-160, C-160-B-161, B-161-A-161, A-161-G-161, G-161-F-161, F-161-E-161, E-161-D-161, D-161-C-161, C-161-B-162, B-162-A-162, A-162-G-162, G-162-F-162, F-162-E-162, E-162-D-162, D-162-C-162, C-162-B-163, B-163-A-163, A-163-G-163, G-163-F-163, F-163-E-163, E-163-D-163, D-163-C-163, C-163-B-164, B-164-A-164, A-164-G-164, G-164-F-164, F-164-E-164, E-164-D-164, D-164-C-164, C-164-B-165, B-165-A-165, A-165-G-165, G-165-F-165, F-165-E-165, E-165-D-165, D-165-C-165, C-165-B-166, B-166-A-166, A-166-G-166, G-166-F-166, F-166-E-166, E-166-D-166, D-166-C-166, C-166-B-167, B-167-A-167, A-167-G-167, G-167-F-167, F-167-E-167, E-167-D-167, D-167-C-167, C-167-B-168, B-168-A-168, A-168-G-168, G-168-F-168, F-168-E-168, E-168-D-168, D-168-C-168, C-168-B-169, B-169-A-169, A-169-G-169, G-169-F-169, F-169-E-169, E-169-D-169, D-169

164

This musical score page features six staves. The top three staves are for Violin (Vn), Viola (Vla), and Violoncello (Vc). The fourth staff is for Percussion (Per), and the fifth and sixth staves are for Piano (Pno). Below these are five empty staves labeled Max1 through Max5. The Vn staff begins with a treble clef and a key signature of one flat, marked *pp*. It contains a melodic line with triplets and a dynamic crescendo to *f*. The Vla staff uses an alto clef, marked *pp* and *mp*, with a dynamic increase to *mf*. The Vc staff uses a bass clef, marked *pp* and *mp*. The Per staff uses a treble clef and features rhythmic patterns with triplets, marked *ff* and *mf*. The Pno staff uses a grand staff (treble and bass clefs) with a *ff* dynamic. The Max1-5 staves are currently empty.

32

169

Vn

Vla

Vc

Per

Pno

Max1

Max2

Max3

Max4

Max5

G

$\text{♩} = 72$
gliss.

ff

f

f

5 Tom-toms

ff

fff

1.217
delayVolL 0 2000;

0.500
au4BrightnessOnOff 0

1.322
whichTracker 0;
matrixPreset 10;
auRecallPreset khDrone7;

0.750
volCycle 1 0 0 1 0

173



Vn *mf* *mp*

Vla *mf* *mp* gliss.

Vc *mf* *mp* gliss.

Per *ff*

Pno *f*

Max1 0.550
ptVolL 0 2000;
matrixPreset 11;
spDelayMax 700;
auRecallPreset2 khTrace8;
spDelayRand 1;
whichTracker 0;

Max2 2.789
delayTimeL 30 2000;
delayFeedbackL 70 1000;

Max3 1.069
delayVolL 65 8000;

Max4

Max5 4.630
volCycle 1 1 1 1 0 0

1.491
delayTimeL 100 10000;

This musical score page features six staves. The top three staves are for Violin (Vn), Viola (Vla), and Violoncello (Vc), each with a treble clef and a 7/8 time signature. The fourth staff is for Percussion (Per), with a treble clef and a 7/8 time signature. The fifth and sixth staves are for Piano (Pno), with treble and bass clefs and a 7/8 time signature. The bottom five staves are for Max1 through Max5, each with a treble clef and a 7/8 time signature. The score is divided into three measures. The first measure (7/8 time) contains a half note with an accent and *sfp* dynamic. The second measure (6/8 time) contains a half note with an accent and *sfp* dynamic. The third measure (6/8 time) contains a half note with an accent and *sfp* dynamic. The Percussion staff has a complex rhythmic pattern in the first measure, including a triplet and a quintuplet, with dynamics *f*, *mp*, and *f*. The Percussion staff is silent in the second and third measures. The Piano and Max staves are silent throughout.

180

sul pont.



Vn staff with notes, dynamics (f, mp), and articulation (sul pont.).

Vla staff with notes, dynamics (f, mf), and articulation (sul pont., gliss.).

Vc staff with notes, dynamics (mf, f, mf), and articulation (sul pont., gliss.).

Per staff with notes, dynamics (p, mf), and articulation (3).

Pno staff with notes, dynamics (f), and articulation (5).

Max1 staff with empty space.

Max2 staff with empty space.

Max3 staff with empty space.

Max4 staff with empty space.

Max5 staff with empty space.

4.028
delayTimeL 20 5000;

36

183

Musical score for Vn, Vla, Vc, Per, Pno, Max1-5. The score is in 7/8 time and consists of 6 measures. The Vn part has a *mp* dynamic. The Vla part has dynamics *f*, *mf*, and *f*, with a *gliss.* marking. The Vc part has dynamics *f*, *mf*, and *f*, with a *gliss.* marking. The Per part has dynamics *f*, *mf*, *ff*, and *mp*. The Pno part is silent. The Max1-5 parts are silent. A box with the text "0.500" and "delayTime: 200-5000;" is located in the Max2 part.

H $\text{♩} = 112$

186

Vn 6/8 *gliss.* 9/8 *ord.* 2/4 *ff*

Vla 12/8 *gliss.* *mf* 6 3 *ff* *ord.* 2/4 *ff*

Vc 6/8 *mf* 9 3 *ff* *f* *ff* *gliss.* 2/4 *ff*

Per 6/8 *mf* 9/8 2/4 *ff*

Pno 6/8 *ff* 5 5 2/4 *f*

Max1 6/8 9/8 2/4

Max2 6/8 1.000 *delayTimeL 15 3000;* 9/8 2/4

Max3 6/8 9/8 0.742 *auRecallPreset3 khGate6;* *auVolL3 55 2000;* 2/4

Max4 6/8 9/8 2/4

Max5 6/8 9/8 2/4 bowed cym 5.209 *volCycle 0 0 0 1 0 0*

7.611
matrixPreset 12;
auRecallPreset khDrone2;
spDelayMax 500;
whichTracker 3;
ptVolL 1000;
paFSwitch 0;
paFPreset 11;
paFTranspose 0;
delayVolL 0 3000;

38

190

Vn

Vla

Vc

ord.

ff

Per

Vibraphone

ff

Pno

Max1

Max2

Max3

Max4

Max5

1.189
pan3Rand 1;
pan3Spread 0.75;
rand3Speed 1500;

1.550
spRecallPreset 5;

196

Vn

Vla

Vc

Per

Pno

Max1

Max2

Max3

Max4

Max5

crot F

crot G

4

5

40

202

Musical score for measures 40-44. The score includes staves for Violin (Vn), Viola (Vla), Violoncello (Vc), Percussion (Per), Piano (Pno), and five Max staves (Max1 to Max5). The Vn, Vla, and Vc parts feature rhythmic patterns with accents and slurs. The Per part includes a complex rhythmic pattern with a 'Ped.' marking. The Pno part features a rhythmic pattern with a 'Ped.' marking. The Max1-5 staves are empty, with 'crot A' and 'crot Bb' markings below the Max5 staff.

6 20

7 20

208

The image shows a musical score for a live performance. The score is divided into several staves:

- Vn (Violin):** Treble clef, playing a rhythmic pattern of eighth notes with a melodic flourish in the middle.
- Vla (Viola):** Alto clef, playing a rhythmic pattern of eighth notes.
- Vc (Violoncello):** Bass clef, playing a rhythmic pattern of eighth notes.
- Per (Percussion):** Treble clef, playing a rhythmic pattern of eighth notes.
- Pno (Piano):** Grand staff (treble and bass clefs), playing a rhythmic pattern of eighth notes.
- Max1:** MIDI controller channel with an annotation: `[0.470]` `matrixPreset 19`.
- Max2:** Empty MIDI controller channel.
- Max3:** Empty MIDI controller channel.
- Max4:** Empty MIDI controller channel.
- Max5:** MIDI controller channel with an annotation: `[0.250]` `volCycle 0 0 0 1 0 0`. It contains a short melodic phrase in purple.

42

214

Musical score for Vn, Vla, Vc, Per, Pno, Max1, Max2, Max3, Max4, and Max5. The score includes dynamic markings *mf* and *ff*, and a section labeled "phrase 7" in red.

Max1

Max2

Max3

Max4

Max5

phrase 7

51 30

220



Vn

Violin staff with notes, slurs, and dynamics (mf).

mf

Vla

Viola staff with notes, slurs, and dynamics (mf, ff).

mf

ff

gliss.

Vc

Violoncello staff with notes and dynamics (mf, ff).

Per

Drum staff with notes and dynamics (ff).

ff

Pno

Piano staff with notes and dynamics (ff, mf).

mf

Max1

Max2

Max3

Max4

Max5

1.356

au2ThresholdOnOff 1

0.654

fmPreset 3

phrase 7b

68 30

Purple musical notation in the Max5 staff.

44

226

Musical score for measures 44-48. The score includes parts for Violin (Vn), Viola (Vla), Violoncello (Vc), Percussion (Per), Piano (Pno), and five Max tracks (Max1 to Max5). The Vn part features a melodic line with dynamics *mp* and *ff*. The Vla and Vc parts have complex rhythmic patterns with dynamics *mf* and *ff*, and include glissando markings. The Per part consists of a steady eighth-note pattern. The Pno part has chords and arpeggios with dynamics *ff* and *mp*. A MIDI controller event is shown in the Max3 track at measure 45, with a value of 0.000 and a name of 'fmPreset 6'.

232

The musical score consists of several staves. The Vn staff features a melodic line with dynamic markings of *mf*, *ff*, *mf*, and *ff*, and a glissando marking. The Vla and Vc staves provide a rhythmic accompaniment with *ff* dynamics. The Per staff has dynamic markings of *p*, *mf*, *ff*, and *p*. The Pno staff includes *f* and *p* dynamics. The Max1-5 staves contain MIDI controller annotations: Max1 has a box with '1.634', 'matrixPreset 13;', and 'pafTranspose -12:'. Max2 has a box with '1.674' and 'au3BinShiftOnOff 1'. Max3 has boxes with '0.977', 'ptVolL 120 4000:', and '0.750', with 'ptRange 76 86' below. Max4 and Max5 are empty.

46

238

Musical score for measures 46-51. The score includes parts for Violin (Vn), Viola (Vla), Violoncello (Vc), Percussion (Per), Piano (Pno), and five Max/MSP channels (Max1-5).

- Vn:** Treble clef, playing a rhythmic pattern of eighth notes.
- Vla:** Bass clef, playing a rhythmic pattern of eighth notes.
- Vc:** Bass clef, playing a melodic line with slurs and dynamics *mp* and *mf*.
- Per:** Treble clef, playing a rhythmic pattern of eighth notes with dynamics *f* and *ff*.
- Pno:** Grand staff (treble and bass clefs), playing a rhythmic pattern of eighth notes with dynamics *f* and *p*.
- Max1:** Contains a box labeled "0.250" with a downward arrow and "spDelay1Rand 1".
- Max2:** Contains a box labeled "0.325" with a downward arrow and "spDelayRand 0".
- Max3:** Contains the text "phrase 2b".
- Max4:** Treble clef, contains a red "b6" and a "4" below the staff.
- Max5:** Bass clef, empty staff.

244

J

Musical score for measures 244-249. The score includes parts for Violin (Vn), Viola (Vla), Violoncello (Vc), Percussion (Per), Piano (Pno), and five Max tracks (Max1 to Max5). The Vn, Vla, and Vc parts are marked *ff*. The Per part is marked *mf*. The Pno part starts with *f* and then *p*. A box in the Max1 track contains the following text: [0.398] whichTracker 0; ptVolL 0 2000; pafTranspose 0; with a downward arrow pointing to the staff line.

48

250

Musical score for measures 48-52. The score includes staves for Violin (Vn), Viola (Vla), Violoncello (Vc), Percussion (Per), Piano (Pno), and five Max/MSP processing channels (Max1-5).

- Vn:** Violin part with a continuous sixteenth-note tremolo pattern.
- Vla:** Viola part with a continuous sixteenth-note tremolo pattern.
- Vc:** Violoncello part with a continuous sixteenth-note tremolo pattern.
- Per:** Percussion part with a melodic line starting in measure 48, marked with *f* and *p* dynamics.
- Pno:** Piano part with a melodic line starting in measure 48, marked with *f* and *mp* dynamics.
- Max1:** Max/MSP channel with a box containing the code: `0.250`, `spDelay1Rand 0;`, `spDelay2Rand 1;`
- Max2:** Max/MSP channel with a box containing the code: `0.750`, `au2ThresholdOnOff 0`
- Max3, Max4, Max5:** Empty Max/MSP channels.

256

The image shows a musical score for a multi-instrument ensemble. The instruments are listed on the left: Vn (Violin), Vla (Viola), Vc (Violoncello), Per (Percussion), Pno (Piano), and Max1-5 (Max/MSP processing). The score is divided into measures. The Vn, Vla, and Vc parts feature dense, rhythmic patterns of eighth notes. The Per part has a more sparse, melodic line. The Pno part has a steady eighth-note accompaniment. The Max1-5 parts are empty, except for a box in Max2 containing the following code: `0.356`, `spDelay2Rand 0;`, `spDelay3Rand 1;`, and `spDelay1Rand 1;`. Below this box is a red arrow pointing down. In Max4, there is a red dot labeled `convolve1` with the numbers `72 78` below it. The Max5 part is empty.

50

262

Vn

Vla

Vc

Per

Pno

Max1

Max2

Max3

Max4

Max5

268

Vn

Vla

Vc

Per

Pno

Max1

Max2

Max3

Max4

Max5

poco a poco dim....

poco a poco dim....

poco a poco dim....

poco dim....

pp [sempre]

pp

Red. (until m. 312 - clear occasionally)

0.030
spDelayRand 1;

0.726
pan3Rand 0

52
274

K

Vn

Vla

Vc

mp *pp*

gliss.

Per

Pno

Max1

Max2

Max3

Max4

Max5

0.748

pan3LocationL 0.5 0.0 1000

1.486

au3BinShiftOnOff 0;

auVolL3 70 2000;

0.000

spRecallPreset 2;

spDelayRand 1;

-0.021

pan3Rotate 8 1 60000

phrase 2b

280

Vn

Vla

Vc

Per

Pno

Max1

Max2

Max3

Max4

Max5

79 35

80 35

54

286

Vn

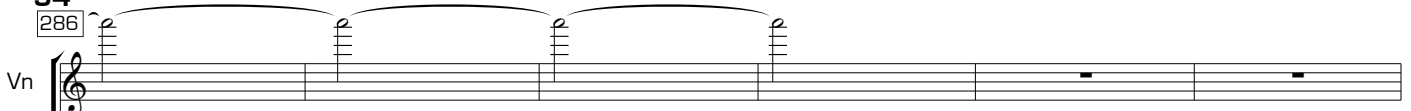

Vla

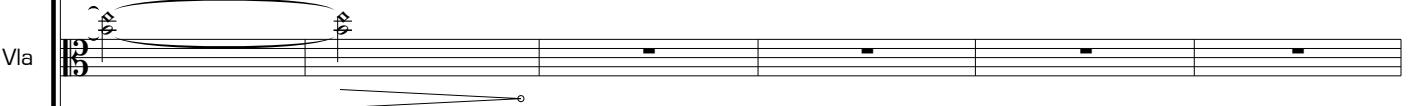

Vc

Pizz.

pp



Per

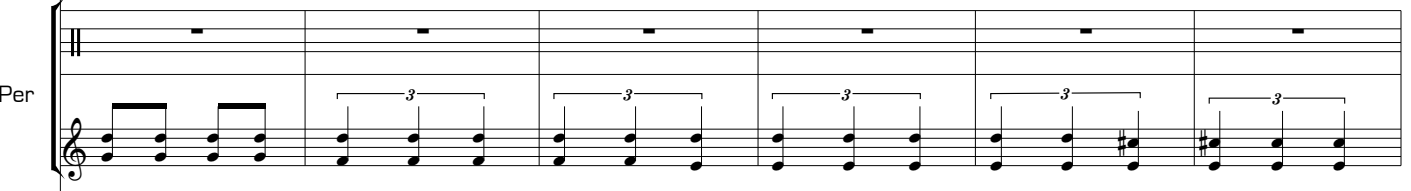

Pno

pp

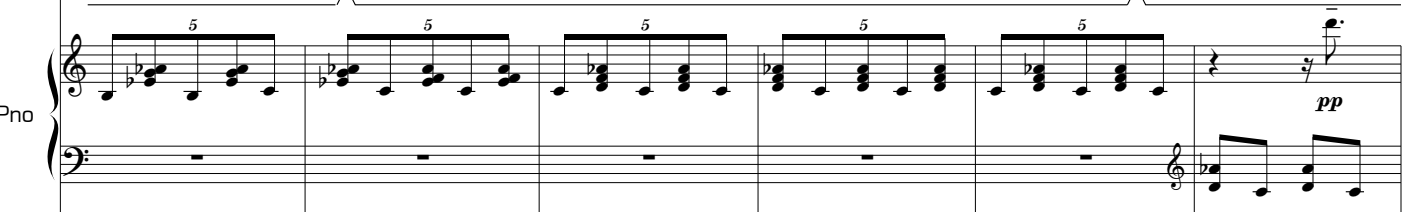

Max1

Max2

Max3

Max4

79 20

Max5

292

Musical score for page 55, measures 292-297. The score is arranged in a system with the following parts:

- Vn** (Violin): Treble clef, rests throughout.
- Vla** (Viola): Bass clef, rests throughout. The instruction "sul pont." is written above the staff at the end of the system.
- Vc** (Violoncello): Bass clef, rests in measures 292-294, then plays a half note in measures 295-297.
- Per** (Percussion): Treble clef, playing a rhythmic pattern of eighth notes with triplets and quintuplets.
- Pno** (Piano): Treble clef, playing a rhythmic pattern of eighth notes with triplets and quintuplets.
- Max1-5** (Maximalist parts): Five empty staves (Max1, Max2, Max3, Max4, Max5) with various clefs (treble and bass).

56

298

sul pont.

pp

pp

Vn

Vla

Vc

The Violin (Vn) part is in treble clef and begins with a whole rest, followed by a half note G#4, then a quarter note G#4, a quarter note F#4, and a quarter note E4, all under a slur. The Viola (Vla) part is in alto clef and begins with a whole rest, followed by a half note G#3, then a quarter note G#3, a quarter note F#3, and a quarter note E3, all under a slur. The Violoncello (Vc) part is in bass clef and begins with a whole rest, followed by a half note G#2, then a quarter note G#2, a quarter note F#2, and a quarter note E2, all under a slur.

Per

The Percussion (Per) part is in treble clef and begins with a whole rest, followed by a half note G#4, then a quarter note G#4, a quarter note F#4, and a quarter note E4, all under a slur. There is a fermata over the final note.

Pno

The Piano (Pno) part is in treble clef and begins with a whole rest, followed by a half note G#4, then a quarter note G#4, a quarter note F#4, and a quarter note E4, all under a slur. There is a fermata over the final note.

Max1

Max2

Max3

Max4

Max5

phrase 2Trans

The Max1-5 parts are in various clefs (Max1-3 are empty, Max4 is treble clef, Max5 is bass clef) and begin with whole rests. The Max5 part has a red circle under the first measure.

304

This musical score page contains six staves. The first three staves are for Violin (Vn), Viola (Vla), and Violoncello (Vc). The fourth staff is for Percussion (Per). The fifth staff is for Piano (Pno), with a grand staff (treble and bass clefs). The last three staves are labeled Max1, Max2, and Max3, and are currently empty. Below these are two more staves labeled Max4 and Max5, which are also empty. The Vn staff features a melodic line with slurs and accents. The Vla staff has a similar melodic line with slurs and accents. The Vc staff has a bass line with slurs and accents. The Per staff has a rhythmic pattern of eighth notes. The Pno staff has a complex texture with slurs and accents. The Max1-5 staves are empty.

58

310

L

Musical score for measures 58-62. The score includes parts for Violin (Vn), Viola (Vla), Violoncello (Vc), Percussion (Per), Piano (Pno), and five Maxima (Max1-5).

- Vn:** Treble clef, *sul tasto*, *ppp*. Long note with hairpins.
- Vla:** Alto clef, *sul tasto*, *ppp*. Long note with hairpins.
- Vc:** Bass clef, *Arco*, *sul tasto*, *ppp*. Long note with hairpins.
- Per:** Treble clef. Includes *Susp. Cymbal* (measures 59-61), *Vibraphone* (measures 61-62), and *bowed* (measure 62). Dynamics: *pp* to *mp* to *p*.
- Pno:** Grand staff, mostly rests.
- Max1-5:** Five staves, mostly rests.

316 $\text{♩} = 56$

Vn ord. at the tip *ppp* *p* *pp* dampen strings with left hand

Vla ord. at the tip *ppp* *p*

Vc ord. at the tip *ppp* *p*

Per bowed *p* *mp*

Pno

Max1 0.090 matrixPreset 15; spRecallPreset 1; spDelayMax 800; spDelayRand 1;

Max2

Max3 0.224 au3BinShiftOnOff 1

Max4

Max5 0.850 volCycle 1 1 1 0 0 1

60
321

Vn
5

Vla
dampen strings with left hand
pp

Vc
gliss.
ppp p ppp

Per
Sizzle Cymbal
pp mp pp
Tam-tam
ppp

Pno

Max1
2/4

Max2
2/4

Max3
2/4

Max4
2/4

Max5
Bell F 25 20
Bell G 26 20
Bell A 27 20
2/4

325

*** Split bridge

* Split bridge

ord. sul A

Vn

Vla

Vc

Per

Pno

Max1

Max2

Max3

Max4

Max5

e a ||||

62

331

ord. sul A

gliss.

ppp *pp* *p*

gliss.

p *mp* *pp*

mp *p* *pp* *ppp*

sul D

Per

bowed

pp *p*

Pno

Max1

Max2

Max3

Max4

Max5

0.070

pan3Rand 1

crotaleA

6 12

*** bow slowly directly on the bridge so that the bow hair is split between the sul pont and sub pont areas

337

M ♩ = 112

The musical score consists of the following parts:

- Vn (Violin):** Treble clef, 4/4 time signature. Rested throughout.
- Vla (Viola):** Treble clef, 4/4 time signature. Rested throughout.
- Vc (Violoncello):** Treble clef, 4/4 time signature. Starts with a glissando (marked *pp*) and a crescendo leading to *ppp*.
- Per (Percussion):** Treble clef, 4/4 time signature. Includes a Vibraphone part starting at measure 337 with a *pp* dynamic.
- Pno (Piano):** Treble and Bass clefs, 4/4 time signature. Features chords and a *pp* dynamic marking.
- Max1-5 (MIDI Controllers):** Five staves with various annotations:
 - Max1:** [0.558] matrixPreset 10; auRecallPreset 4; khGate2; spDelayMax 300; pitchTrackerOnOff 0;
 - Max2:** [0.750] au3BinShiftOnOff 0;
 - Max5:** [0.325] volCycle 1 1 1 1 1

This musical score page features six staves. The top three staves are for Violin (Vn), Viola (Vla), and Violoncello (Vc), each starting with a *pp* dynamic marking. The fourth staff is for Percussion (Per), with a *p* dynamic marking. The fifth staff is for Piano (Pno), showing both treble and bass clefs. The bottom three staves are labeled Max1, Max2, and Max3, followed by Max4 and Max5. The time signature changes from 4/4 to 3/4, 2/4, 5/4, and back to 4/4 across the measures. The score includes various musical notations such as notes, rests, slurs, and dynamic markings.

347

Vn *mp*

Vla *mp*

Vc *mp*

Per *mp*

Pno *mp*

[clear pedal occasionally]

Max1

Max2

Max3

Max4

Max5

3.457
volCycle 1 1 1 0 0 0

66

350

Musical score for measures 66-68. The score includes parts for Violin (Vn), Viola (Vla), Violoncello (Vc), Percussion (Per), Piano (Pno), and five Max tracks (Max1-5). The Vn part features a melodic line with dynamics *mf* and *p*. The Vla part has a rhythmic accompaniment with dynamics *mp*, *f*, and *mp*. The Vc part has a rhythmic accompaniment with dynamics *f* and *f*. The Per part has a rhythmic accompaniment with dynamics *f* and *mp*. The Pno part has a rhythmic accompaniment with dynamics *f* and *mp*. The Max tracks are empty.

N

353

Musical score for Vn, Vla, Vc, Per, Pno, and Max1-5. The score is divided into three measures. The Vn part starts with a fermata over a whole note, then a rest, followed by eighth notes. The Vla part has a melodic line with dynamics *mp*, *f*, and *mp*. The Vc part has a steady eighth-note accompaniment with dynamics *f* and *f*. The Per part has a melodic line with dynamics *f*. The Pno part has a steady eighth-note accompaniment with dynamics *f* and *f*. The Max1-5 parts are empty.

This musical score page features six staves. The first three staves are for Violin (Vn), Viola (Vla), and Violoncello (Vc). The fourth staff is for Percussion (Per), and the fifth is for Piano (Pno). The bottom three staves are labeled Max1, Max2, and Max3, with Max4 and Max5 below them. The Vn, Vla, and Vc parts consist of continuous sixteenth-note patterns with dynamic markings of *f* and *mp*. The Per part has a melodic line with *f* and *mp* dynamics. The Pno part features a steady accompaniment with a *f* dynamic marking. The Max1-5 staves are currently empty.

359

Musical score for measures 359-361. The score includes parts for Violin (Vn), Viola (Vla), Violoncello (Vc), Percussion (Per), Piano (Pno), and five Max parts (Max1-5). The Vn, Vla, and Vc parts feature dynamic markings of *f* and *mp*. The Per part has *f mp* markings. The Pno part has *f* markings. The Max parts are empty.

This musical score page features six staves. The top three staves are for Violin (Vn), Viola (Vla), and Violoncello (Vc), each with a treble and bass clef. The fourth staff is for Percussion (Per) with a treble clef. The fifth staff is for Piano (Pno) with a grand staff (treble and bass clefs). The bottom three staves are labeled Max1, Max2, Max3, Max4, and Max5, with Max4 and Max5 having treble and bass clefs respectively. The score contains rhythmic patterns with dynamic markings such as *f*, *mp*, and *ff*. Slurs and hairpins are used to indicate phrasing and dynamics. A dashed line is present in the Pno staff in the third measure.

365 **0**

Vn *f mp f*

Vla *f mp f mp*

Vc *f mp f mp f*

Per *ff ff*

Pno *ff mp ff*

Wood blocks
Tom-toms

Max1

Max2

Max3

Max4

Max5

72
368

Musical score for Vn, Vla, Vc, Per, Pno, and Max1-5. The score is divided into measures 72, 73, and 74. The Vn, Vla, and Vc parts feature complex rhythmic patterns with dynamic markings of *mp*, *f*, and *mp*. The Per part has a simple rhythmic pattern. The Pno part features a melodic line with dynamic markings of *mp*, *ff*, and *mp*. The Max1-5 parts are empty.

2.924
au2ThresholdOnOff 1;
au3BinShiftOnOff 1;
auVolL3 60 1000;

371

This musical score page contains measures 371 through 373. The instruments and their parts are as follows:

- Vn (Violin):** Plays a continuous sixteenth-note pattern. Dynamics are marked *f* (measures 371-372), *mp* (measure 373), and *f* (measures 374-375).
- Vla (Viola):** Plays a continuous sixteenth-note pattern. Dynamics are marked *f* (measures 371-372) and *mp* (measures 373-375).
- Vc (Violoncello):** Plays a continuous sixteenth-note pattern. Dynamics are marked *f* (measures 371-372), *mp* (measures 373-374), and *f* (measures 375-376).
- Per (Percussion):** Features a rhythmic pattern of eighth notes with accents, alternating with rests.
- Pno (Piano):** Features a melodic line with slurs and dynamic markings of *ff* (measures 371, 375) and *mp* (measures 372-374).
- Max1-5:** Five empty staves, with Max4 and Max5 including clefs.

377

P

Vn $\frac{2}{4}$ $\frac{4}{4}$ *ff* *mf* poco a poco dim....

Vla $\frac{2}{4}$ $\frac{4}{4}$ *ff* *mf* poco a poco dim....

Vc $\frac{2}{4}$ $\frac{4}{4}$ *ff* *mf* poco a poco dim....

Per $\frac{2}{4}$ $\frac{4}{4}$ *f*

Pno $\frac{2}{4}$ $\frac{4}{4}$ *fff* *ff* poco a poco dim....

Max1 $\frac{2}{4}$ $\frac{4}{4}$

Max2 $\frac{2}{4}$ $\frac{4}{4}$

Max3 $\frac{2}{4}$ $\frac{4}{4}$

Max4 $\frac{2}{4}$ $\frac{4}{4}$

Max5 $\frac{2}{4}$ $\frac{4}{4}$

```

3.000
au2ThresholdOnOff 0;
au3BinShiftOnOff 0;
auVolL3 70 5000;

```

76

380

This musical score page contains measures 76, 77, and 78. The instruments and parts are as follows:

- Vn (Violin):** Treble clef, playing a rhythmic pattern of eighth notes with slurs.
- Vla (Viola):** Bass clef, playing a rhythmic pattern of eighth notes with slurs.
- Vc (Violoncello):** Bass clef, playing a rhythmic pattern of eighth notes with slurs.
- Per (Percussion):** Two staves. The top staff has a box labeled "Tam-tam (metal)" with a double bar line and a note. The bottom staff has a note marked *ppp*.
- Pno (Piano):** Grand staff (treble and bass clefs). The right hand plays a rhythmic pattern of eighth notes, and the left hand plays a similar pattern. A dynamic marking of *mp* is present in measure 78.
- Max1, Max2, Max3:** Empty staves.
- Max4, Max5:** Empty staves.

383

The image shows a musical score for a piece, page 77, starting at measure 383. The score is arranged in a system with six staves. The first three staves are for Violin (Vn), Viola (Vla), and Violoncello (Vc). The fourth staff is for Percussion (Per). The fifth staff is for Piano (Pno). The last three staves are labeled Max1, Max2, and Max3, with Max4 and Max5 below them. The Vn, Vla, and Vc parts feature dynamic markings of *p* and *pp*, and include triplet markings. The Per part has a *mp* marking. The Pno part has *p* and *pp* markings. The Max1 and Max3 staves contain MIDI controller messages: Max1 has a message box with the value 0.437 and the text 'matrixPreset 17;', and Max3 has a message box with the value 0.700 and the text 'au1BrightnessOnOff 1'. Both message boxes have a downward-pointing arrow.

78

387

♩ = 56

Q

♩ = 72

Vn

Vla

Vc

Per

Pno

Max1

2.395

spDelayMax 800;
auRecallPreset khDrone4;
spRecallPreset 4;

2.330

matrixPreset 18;
spDelayMax 1000;

Max2

0.107

sfPlayerVol: 20 1000;

Max3

Max4

Max5

0.750

volCycle 1 1 1 1 1 1

2.250

volCycle 1 1 1 1 1 1

sung F

394

Vn

Vla

Vc

Per

Pno

Max1

Max2

Max3

Max4

Max5

p

pp

mp

ppp

p

p

mp

bowed

phrase 9

54 24

80

399

♩ = 56

Vn *pp* *ppp*

Vla *pp* *ppp*

Vc *pp* *ppp*

Per *pp*

Pno *ppp*

Max1 3/4 4/4 3.500 au1BrightnessOnOff 0

Max2 3/4 4/4 0.270 pafPreset 12 2.738 pan1Rand 0; pan2Rand 0; pan3Rand 0;

Max3 3/4 4/4

Max4 3/4 4/4 sung F 77 20 78 15 79 12

Max5 3/4 4/4

